

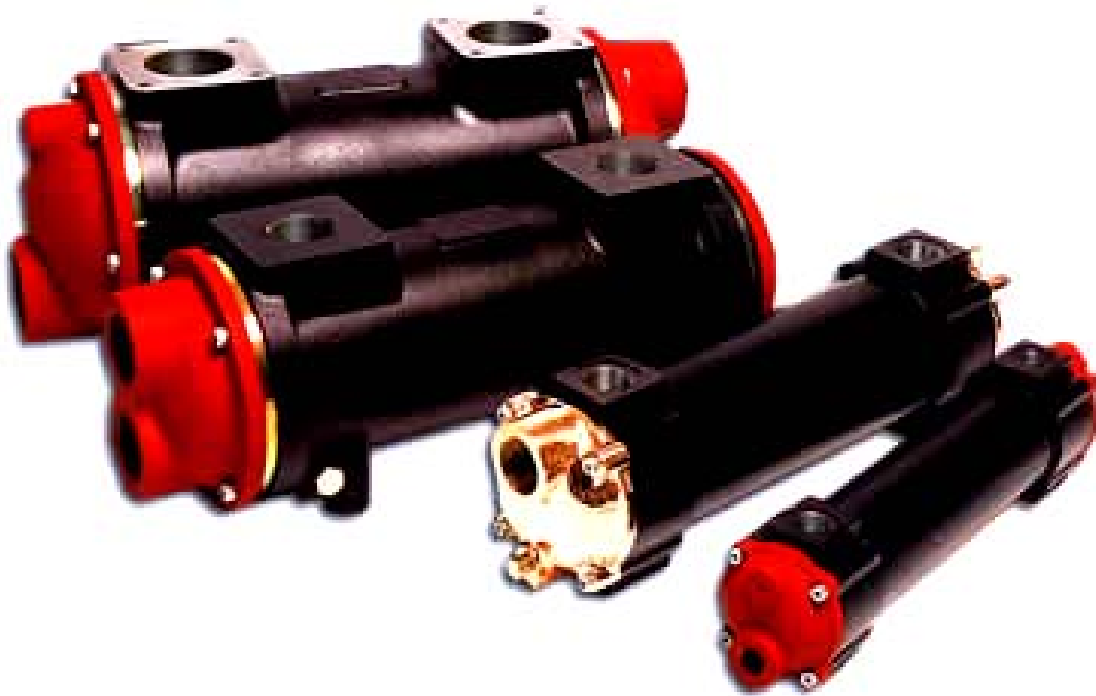

HYDRAULIC OIL COOLER INSTALLATION & MAINTENANCE MANUAL



Thermex Ltd
Merse Road, North Moons Moat,
Redditch, Worcestershire. B98 9HL
Tel: ++44 (0) 1527 62210 Fax: ++44 (0) 1527 60138
Web: www.thermex.co.uk / email: enquiry@thermex.co.uk

INSTALLATION

The coolers may be mounted either horizontally or vertically but the pipe work should always be designed such that the water inlet is adjacent to the oil outlet, i.e. with flow of water and oil in opposite directions (counter flow). When mounting horizontally, venting is assisted if the water outlet positioned facing upwards.

Long lengths of unsupported pipe work should be avoided and if the installation is subject to severe vibration, flexible hoses should be used or alternatively a flexible compensator flange (also available from Thermex Ltd).

The cooler should ideally be installed in the return line to the tank, however where large fluctuations in flow or pressure are likely, we recommend that the cooler is mounted off-line with a separate re-circulating pump.

In cold weather, a check valve to bypass oil around the cooler is recommended for oils with a high viscosity. Care should be taken to prevent the cooling water from freezing if the cooler is exposed to harsh winter conditions.

If cooling with seawater, we strongly recommend that the specified water flow rates are observed. Both too little and too much seawater flow can cause erosion within the cooler.

If fitting a temperature control valve, make sure it is installed on the water side and on the inlet to the cooler.

Provision is made for mounting the cooler using the following bolt sizes: 2300 Series = M6, 2500Series = M8, 2700 & 2800 series = M12. Double seals and witness rings are provided on the 2700 & 2800 series units with a small leak detection hole in the witness ring, so that in the unlikely event of a seal failure, the second seal will protect from cross contamination whilst the small leak from the detection hole will alert the user to conduct repairs.

OPERATING CONDITIONS

Maximum operating pressure: Through Tubes (Water) = 10 Bar
Over Tubes (Oil) 2300 & 2500 Series = 30 Bar
2700 & 2800 Series = 20 bar

Maximum operation temperatures: 100°C (Nitrile seals)
120°C (Viton seals)

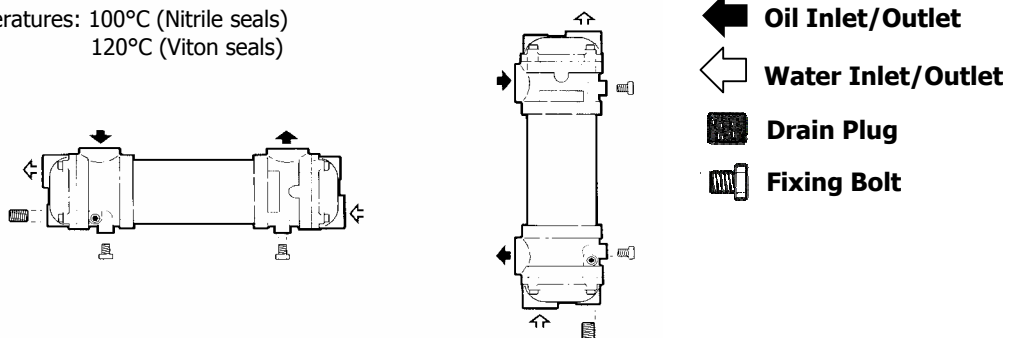

DISMANTLING

After removal of the cap screw securing the headers to the body (and Witness rings, where fitted) the O-rings can be taken off and the tubestack removed from either end.

SERVICING

The tubestack should first be degreased using a suitable solvent. Any heavy contamination on the oil side can be removed by a high pressure water wash. On no account should any sharp object be used for removing contamination due to danger of piercing the tubes. Any contamination inside the tubes can also be removed with a high pressure water wash or for more stubborn deposits, by a using a special cleaning rod (available from Thermex Ltd).

Conventional cleaning methods should be applied to the headers and body. Any severely corroded headers should be replaced immediately and extra care and attention should be taken when cleaning the body and headers to avoid damage to the sealing surfaces.

ASSEMBLY

The tubestack should be placed in the body with the arrow on the face of the tubeplate aligned with the arrow on the end of body. This ensures that the baffles are correctly positioned relative to the ports. The headers (and witness rings where applicable) should be fitted with new O-rings and water seals. Before fitting new O-rings, they should be lubricated with clean hydraulic oil. The cap screws should be fully tightened in sequence to avoid distortion, applying the following torque loadings:

M6 = 10 Nm

M8 = 25 Nm

M10 = 55 Nm

TESTING

The complete cooler should be immersed in clean water and an air pressure of 4 bar applied to the oil side (Shell side). Any leakage will be detected by air bubbles escaping from the defective component, which should then be replaced.

CONSTRUCTION OF STANDARD THERMEX HYDRAULIC OIL COOLERS

2300 & 2500 Series

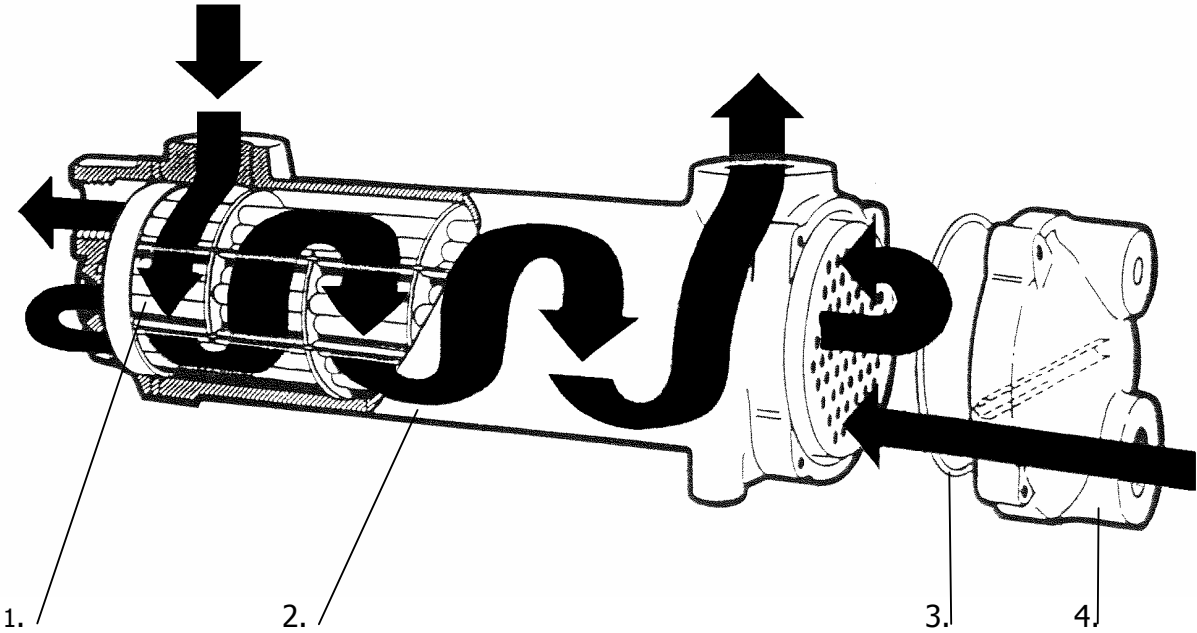

1. Tubestack 2. Body 3. Seals 4. Header

2700 & 2800 Series

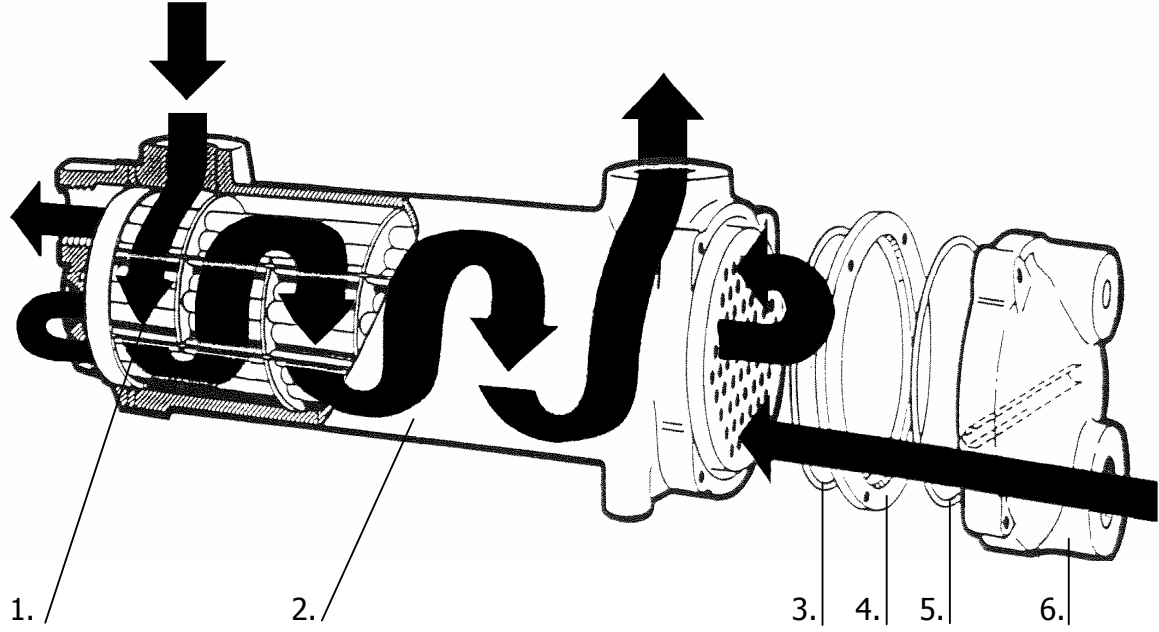

1. Tubestack 2. Body 3 & 5. Seals 4. Witness ring 6. Header